

SEISMIC INSTALLATION OF FAN-COIL UNITS AND BLOWER COIL UNITS

INSTALLATION & OPERATION MANUAL

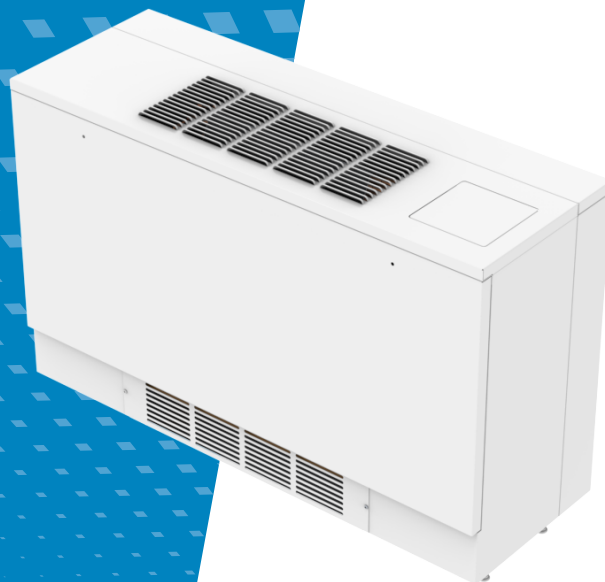
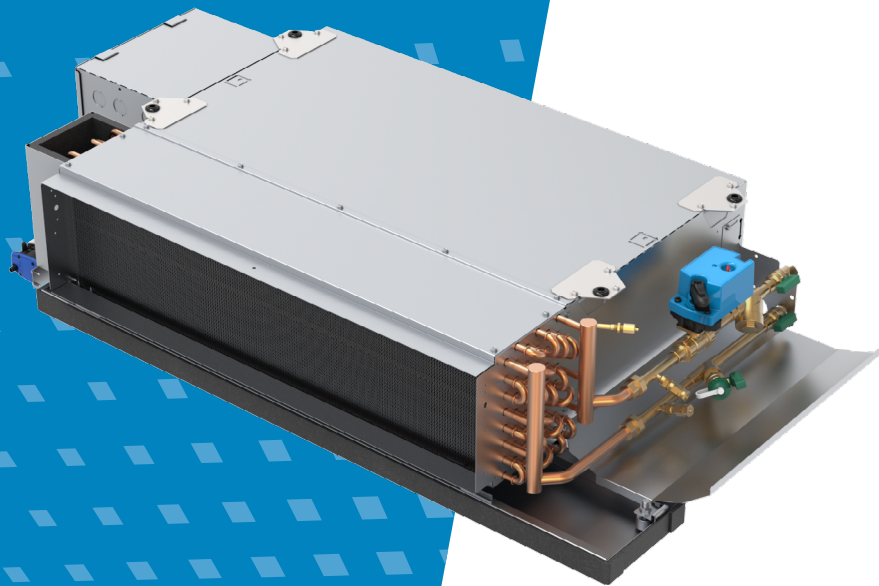

TABLE OF CONTENTS

Introduction	3
Model SBHD Ceiling-Mounted Units	4
Model RAH Ceiling-Mounted Units	5
Model RBH Ceiling-Mounted Units	6
Model RBV and RBVL/RBVD Floor-Mounted Units	7
Model SBVD Floor-Mounted Units	8
Model RAV Floor-Mounted Units	8
Model RAVC Floor-Mounted Units	9
Model SSB/SSL Floor-Mounted Units	10

ALL DATA HEREIN IS SUBJECT TO CHANGE WITHOUT NOTICE
Refer to www.superiorrex.com for current catalog data and submittal drawings.

INTRODUCTION

Superior Rex fan-coil units and blower-coil units which are applied in facilities subject to seismic activity have special construction features and need to be installed as detailed in this document. They can be identified by their seismic labels, which are similar to the example label in Figure 1. The label lists:

- The unit model
- The applicable test standard(s)
- The applicable building code(s)
- The seismic-resistance test value

The certified Sds rating shown on the label is only IBC-certified when installed in accordance with this document. Installations which deviate from these procedures must be approved by an engineer licensed for seismic certification.

Cables, threaded rods, and other miscellaneous items are to be supplied by others. Items mounted in the field (such as piping packages, electrical panels, ductwork, etc.) to IBC seismically certified HVAC equipment are not considered part of the equipment certification. Field-mounted items are required to be supported and restrained in accordance with recommended seismic installation practices and may include, but not necessarily be limited to, the use of flexible piping connectors. The installation of these field-mounted items, and any restraints / supports, is the responsibility of the installing contractor.

This seismic installation document is intended to supplement the standard Installation, Operation, Maintenance manual, and shall take precedence over the standard manual in areas where overlap occurs. This document is organized by Model.

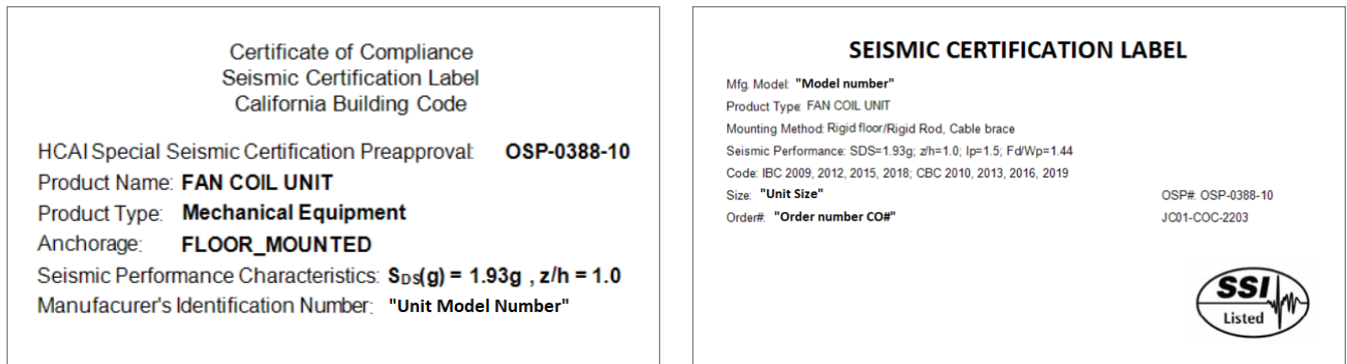

FIGURE 1 - SAMPLE LABEL FROM A SEISMIC-RATED FAN-COIL UNIT

MODEL SBHD CEILING-MOUNTED UNITS

NOTES:

For all models, unit size can change the installation method.

SIZES 08-20

Unit is hung from the ceiling using strut screwed to both the top and bottom of the unit on both the front and the back. See Figure 2.



FIG. 2 - SECTIONS OF STRUT ARE USED TO HANG THE UNIT

A 1/2-inch threaded rod is run through the base rail on the bottom of the unit and the solid rail on the top of the unit. Each rod is stiffened with unistrut, and B-line, 1/2-inch clips, spaced no more than 22 inches on center. Lateral bracing is provided by 14-gauge, 45-degree brackets, washers, and 3/16-inch cable with four saddle clamps (wire rope grips) per cable (two grips at each connection). Grips are installed as per FEMA 414. See Figure 3.



FIG. 3 - LATERAL SUPPORT COMPONENTS FOR SBHD 08-20

Also, see Table 1 for list of brackets supplied by Superior Rex. Brackets as listed are minimum gauge thickness. Actual thickness may vary.

MODELS	BRACKETS (PER UNIT)
SBHD 08 to 20	Four 45-degree, 12-gauge brackets
SBHD 30 & 40	Four 45-degree, 12-gauge brackets
	Four 3" x 3" 12-gauge plate washers
	Eight 4" x 4" 12-gauge plate washers

TABLE 1 - BRACKETS SUPPLIED BY SUPERIOR REX

SIZES 30 & 40

Threaded rod, 5/8-inch diameter, grade 2, is run through the manufacturer-supplied, 12-gauge, 1-5/8-inch strut on the bottom of the unit, and the solid strut screwed to the top of the unit. See Figure 4.



FIG. 4 - RECOMMENDED LENGTH OF THREADED ROD

The unit shall be laterally braced using 45-degree, 12-gauge, galvanized-steel, outside angle brackets and 3/8-inch diameter, general-purpose cable (6 x 19 Class IWRC) with four saddle clamps (wire rope grips) per cable (two grips at each connection). Grips are installed as per FEMA 414.

Each bracket shall attach to the frame using a 1/2-inch, grade 5 bolt. The brackets attached to the solid strut at the top of the unit shall be sandwiched between one 3-inch square, 12-gauge plate washer on the bottom and two 4-inch square, 12-gauge plate washers on top.

MODEL RAH CEILING-MOUNTED UNITS

Unit is ceiling-mounted using one 12-gauge, 90-degree bracket, one 12-gauge, flat bracket, and one 12-gauge, 45-degree bracket at each of the mounting points. The flat bracket and the 90-degree bracket attach to the unit using four #12, 3/4-inch sheet metal screws. The flat bracket overlaps the 90-degree bracket. The 45-degree bracket is located on top of the flat bracket. A 1/2-inch, threaded rod is run through the flat bracket, 90-degree angle bracket, and 45-degree angle bracket, and a nut and washer are placed on the top and the bottom of the brackets. See Figure 5.



FIG. 5 - OVERLAPPED FLAT, 90° AND 45° BRACKETS

Each threaded rod is stiffened using a length of unistrut and three B-line, 1/2-inch clips. Clips are placed two inches from the top and bottom of the unistrut, and one is placed at the approximate middle. Lateral bracing is accomplished using 12-gauge, 45-degree brackets. Brackets are attached to 3/16-inch cable with four saddle clamps (wire rope grips) per cable (two grips at each connection). Grips are installed as per FEMA 414. It is recommended that the cables be adjusted prior to final tightening of the top locking nut on the threaded rod. See Figure 6. Also, see Table 2 for Superior Rex supplied brackets.

MODELS	BRACKETS (PER MOUNTING POINT)
RAH	One 3" x 6" x 12-gauge plate – 90-degree
	One 2" x 6" x 12-gauge plate – 45-degree
	One 3" x 6" x 12-gauge plate – flat

TABLE 2 - BRACKETS SUPPLIED BY SUPERIOR REX

Hanger brackets listed above are minimum gauge thickness requirements. Actual thickness may vary. An instructional document will ship with the units, detailing the locations where the brackets should be installed.



FIG. 6 - UNISTRUT USED TO STRENGTHEN THE ROD

MODEL RBH CEILING-MOUNTED UNITS

Unit is ceiling-mounted using two 12-gauge, 45-degree brackets, and one 12-gauge, flat bracket at each of the mounting points. Each 45-degree bracket is located below the flat bracket. A 1/2-inch, threaded rod is run through each flat bracket and 45 degree angle bracket, and a nut and washer placed on the top and the bottom of the brackets. See Figure 7.



FIG. 7 - OVERLAPPED FLAT AND 45° BRACKETS



FIG. 8 - UNISTRUT USED TO STRENGTHEN THE ROD

Each threaded rod is stiffened using a length of unistrut and three B-line, 1/2-inch clips. Clips are placed two inches from the top and bottom of the unistrut, and one is placed at the approximate middle. Lateral bracing is accomplished using 12-gauge, 45-degree brackets. Brackets are attached to 3/16-inch cable with four saddle clamps (wire rope grips) per cable (two grips at each connection). Grips are installed as per FEMA 414. It is recommended that the cables be adjusted prior to final tightening of the top locking nut on the threaded rod. See Figure 8. Also, see Table 3 for Superior Rex supplied brackets.

MODELS	BRACKETS (PER MOUNTING POINT)
RBH	Two 2" x 6" x 12-gauge plate – 45 degree
	One 3" x 3" x 12-gauge plate – flat

TABLE 3 - BRACKETS SUPPLIED BY SUPERIOR REX

Hanger brackets listed above are minimum gauge thickness requirements. Actual thickness may vary.

MODEL RBV AND RBVL/RBVD FLOOR-MOUNTED UNITS

FULL-SIZED UNITS (RBV)

Unit is mounted at the bottom using two angle clips (one on each front bottom corner of the unit) and at the back-side using the manufacturer provided mounting holes. Attach each angle clip using four #12, 3/4-inch long, sheet metal screws, with two screws attached through the unit and two screws through the building floor. The back-side, manufacturer provided mounting holes are used to secure the unit to the building wall using #12, 3/4-inch long, sheet metal screws, or similar anchors based on the building material used. Front clips are installed to the concealed cabinet housing, internal to the painted cabinet of the units. See Figure 9.

LOW-PROFILE UNITS (RBVL/RBVD)

Unit is mounted at the bottom and at mid-height using four angle clips (one on each back-side, equal distance from top and bottom of the unit, and one on each front-bottom corner of the unit). Attach each clip using four #12, 3/4-inch long, sheet metal screws or similar anchors based on the building material used, with two screws attached through the unit, and two screws through the building wall/floor.

Front clips are installed to the concealed cabinet housing internal to the painted cabinet of the unit. See Figure 9. Also, see Table 4 for Superior Rex supplied brackets.



FIG. 9 - FRONT CLIPS ATTACHED TO UNPAINTED SHEET-METAL FRAME

MODELS	BRACKETS (PER MOUNTING POINT)
RBV	Two 90-degree brackets
RBVL/RBVD	Four 90-degree brackets

TABLE 4 - BRACKETS SUPPLIED BY SUPERIOR REX

MODEL SBVD FLOOR-MOUNTED UNITS

The vertical blower coil shall be attached to the structure with a 1/2" x 1-3/4" (ASTM A307 cap screw) bolt at each of the four corners of the factory-supplied base rail. Each bolt shall use a standard washer. See Figure 10.



FIG. 10 - BOLT AT EACH BASE-RAIL CORNER

MODEL RAV FLOOR-MOUNTED UNITS

Unit shall be mounted at the bottom and back using four manufacturer provided angle clips (one on each front-bottom corner, and one on each side). Side mounted clips shall be 58.5 inches from the bottom of the unit.

Attach each clip using four #12, 3/4" long sheet metal screws or similar anchor for building material being used; two screws attached through the unit, and two screws through the building wall/floor. See Figure 11. Also, see Table 5 for Superior Rex supplied brackets.

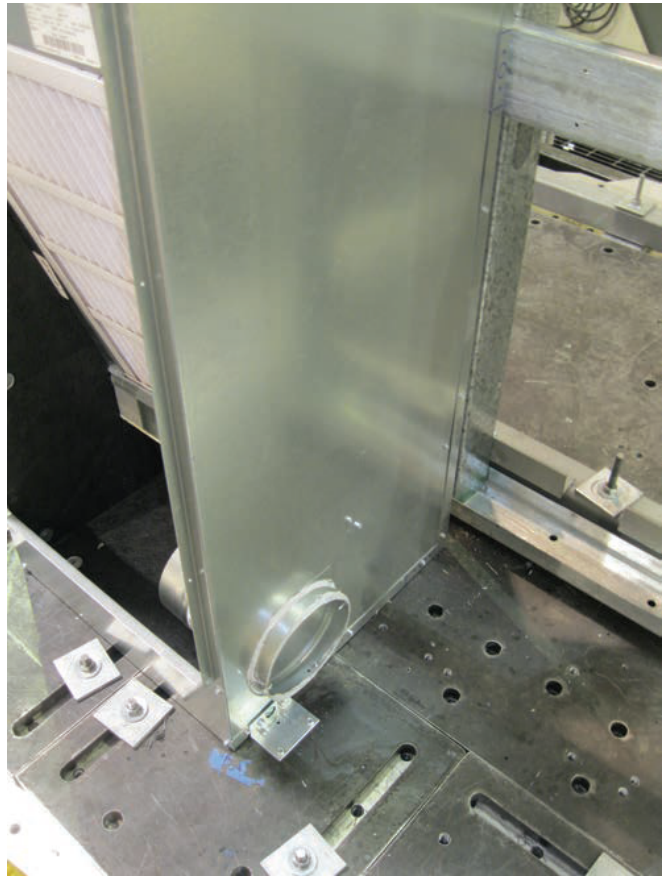

FIG. 11 - MANUFACTURER-SUPPLIED ANGLE CLIP

MODEL RAVC FLOOR-MOUNTED UNITS

Unit shall be secured at the bottom and back using four manufacturer-provided angle clips (one on each front-bottom corner, and one on each side). Installation of side-mounted clip height will vary dependent on unit size and if a air-mixing box has been selected. On unit sizes 04-08 with a mixing box, install brackets 55 inches from the bottom of the unit. On unit sizes 10-20 with a mixing box, install brackets 58 inches from the bottom of the unit. If no mixing box is present, install brackets 40 inches from the bottom of the unit. Attach each clip using four #12, 3/4" long sheet metal screws or similar anchor for building material being used; two screws attached through the unit, and two screws through the building wall/floor. See Figure 12. Also, see Table 5 for Superior Rex supplied brackets.

MODELS	BRACKETS (PER MOUNTING POINT)
RAV	Four 90-degree brackets
RAVC	Four 90-degree brackets

TABLE 5 - BRACKETS SUPPLIED BY SUPERIOR REX

Hanger brackets listed above are minimum gauge thickness requirements. Actual thickness may vary. An instructional document will ship with the units detailing the location that the brackets should be installed.

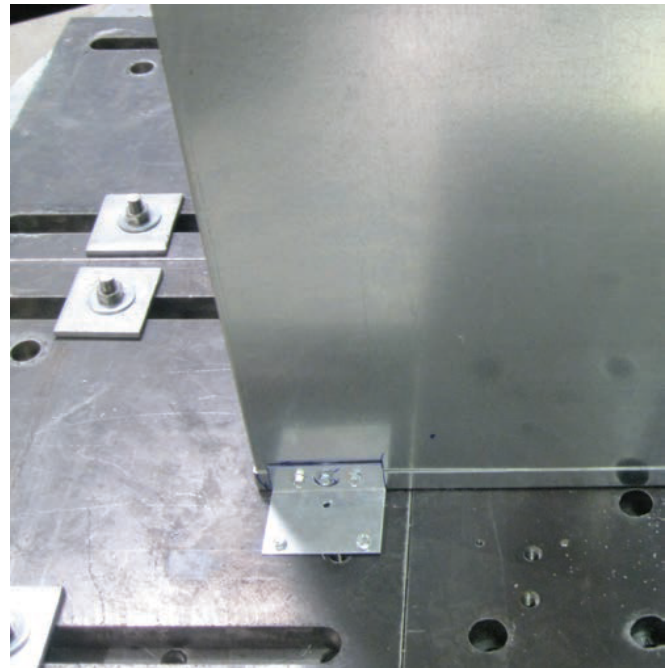

FIGURE 12 - MANUFACTURER-SUPPLIED ANGLE CLIP

MODEL SSB/SSL FLOOR-MOUNTED UNITS

The vertical blower coil shall be attached to the structure with 1/2" x 1-3/4" (ASTM A307 cap screw) bolt at each of the four corners of the factory supplied base rail. Each bolt shall use a standard washer. See Figure 13.

A sheet metal duct shall be attached to the ducted discharge on top of the electric heater with eight #10 sheet metal screws. Two screws shall be attached on each side, seven inches apart on the short side, 10-inches apart on the long side. The sheet metal discharge duct shall be 2-foot long, by the width and depth dimensions of the unit discharge. A minimum of 20-gauge shall be used. Supply ductwork shall be rigidly supported 2 feet downstream of the blower coil discharge. Appropriate flex connector(s) and duct transition(s), installed as required, must be installed downstream of support location.

No flex connection is to be installed between unit and support bracket. The sheet metal duct shall be attached to support bracket with a minimum of four #14 sheet metal screws. Two screws shall be installed on the front and back, spaced 1-inch from the corners. See Figure 14.

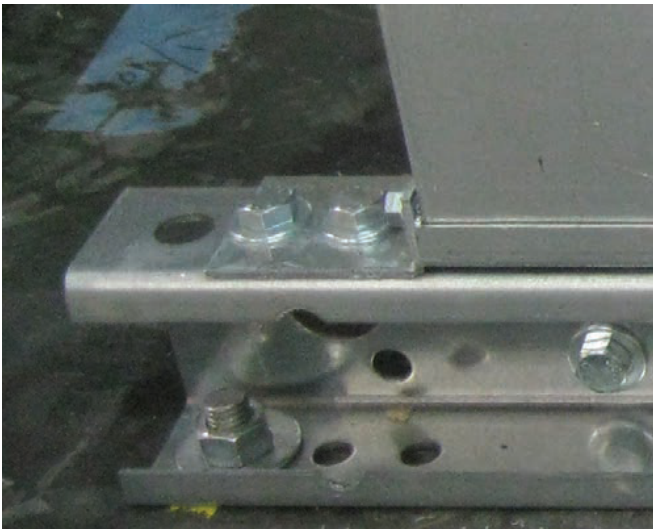

FIG. 13 - BOLT AT EACH BASE-RAIL CORNER

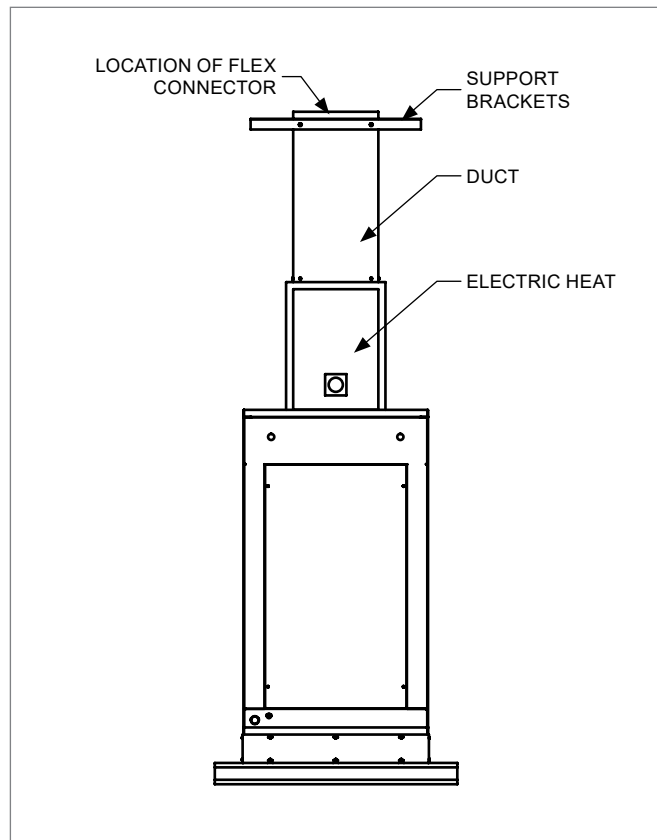

FIG. 14 - DUCTWORK SUPPORT

APPENDIX COMPONENT INSTALLATION, OPERATION & MAINTENANCE MANUALS

Fan Coil Relay Board (FRBII) Installation, Operation & Maintenance

Electric Heat, All Products Installation, Operation & Maintenance

Analog Thermostats – Data and Instructions

Digital Thermostat (D-Series) – Installation Guide

Digital Thermostat (D-Series) – Operating Manual

Programmable Thermostat (P-Series) – Installation Guide

Programmable Thermostat (P-Series) – Operating Manual

N-Series and F-Series TEC3000 – Installation Instructions

For the supplemental installation, operation and maintenance manuals listed above, please contact your local Sales Representative or visit www.superiorrex.com

